



LP-7515 INDICATOR USER'S MANUAL



TABLE OF CONTENTS

Safety Precautions	3
Preparations and Set Up	3
Features	2
Specifications	3
Power Supply	4
Displays	5
Display and Key Descriptions	5
Operating Instructions	6
Calibration	8
Indicator Parameter Settings	10
Troubleshooting	12
Connectors	13
RS232 Serial Output Format	14
Specifications	15

SAFETY PRECAUTIONS

For safe operation of the weighing indicator, please follow these instructions:

- Calibration inspection and maintenance of the indicator are prohibited by non-professional staff
- Please ensure that the indicator rests on a stable surface
- The indicator is a piece of static sensitive equipment; Please cut off power during electrical connections
- Touching the internal components by hand is prohibited
- DO NOT exceed the rated load limit of the unit
- DO NOT step on the unit
- DO NOT jump on the scale
- DO NOT use this product if any of the components are cracked
- DO NOT use for purposes other than weight taking
- To avoid damaging the battery do not keep charger plugged in once battery is fully charged
- Make sure the weight is not over the Max capacity as it could damage the load cell inside
- Material that has a static electric charge could influence the weighing. Discharge the static electricity of the samples, if possible. Another solution to the problem is to wipe both sides of the pan and the top of the case with an anti-static agent

Please take anti-static prevention measures

Any accumulated charge on the body of the human operator should be discharged first before opening the protective container with ESDS devices inside. The discharge can be accomplished by:

- Putting a hand on a grounded surface or, ideally, by wearing a grounded Anti-static Wrist Strap and an Anti-static Mat

PREPARATION & SET UP

- Plug into a wall outlet to avoid interference with other wirings
- Turn on the balance while there is no load
- We suggest to warm-up the balance by powering on 5 minutes before use for accurate weighing
- Calibration may be required before weighing when the balance is initially installed or moved from a location

FEATURES

- Smooth indicator shape with steady performance PCB board, is suitable for industrial or commercial use
- Multiple weighing units: (lb/oz/kg)
- Gross/Tare/Zero
- Low power design, longer battery usage time
- Hold function, locks the weight
- Idle mode and automatic power off function
- Low-battery detection and warning
- 6 digits 0.7" tall LCD display with backlight
- Splash proof keyboard and display
- RS232 Output
- Print to an optima scale ticket printer
- Stainless steel wall mount bracket included

TECHNICAL PARAMETERS



- Accuracy class: OIML III, n=3000e
- Tare range: 2%~100% max. capacity
- Initial zero range: $\pm 10\%$ max. capacity
- Manual zero range: $\pm 2\%$ max. capacity
- Resolution - Display: Up to 1/15,000 Display Resolution
- Operation temperature: $-10\text{ }^{\circ}\text{C} \sim +40\text{ }^{\circ}\text{C}$
- Operation humidity: $\leq 90\%$ RH
- Storage temperature: $-40\text{ }^{\circ}\text{C} \sim +70\text{ }^{\circ}\text{C}$ (32-104°F)

POWER SUPPLY

- The indicator uses 3 AAA batteries which will work for about 30 hours with the backlight turned on, if you turn off the backlight the battery can last up to 100 hours
-  This low battery icon will display when the indicator detects low battery, if not replaced in time the indicator will power off automatically
- If you are using the included DC power supply, the indicator will not use battery power
- Plug the adapter directly into the "DC" pin located at the back of the indicator. We recommend to plug into a wall outlet to avoid interference with other wirings

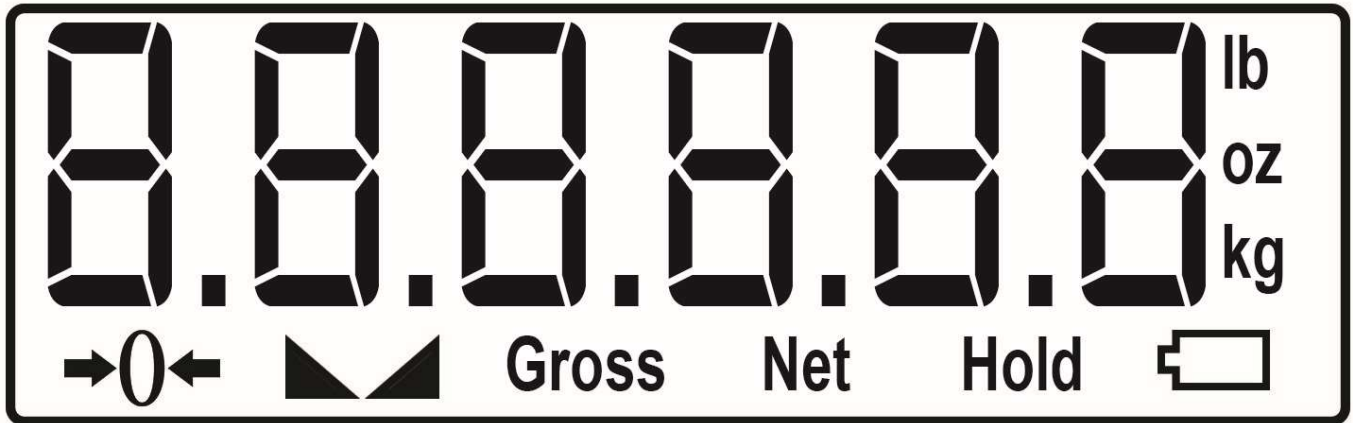
DISPLAY AND KEY DESCRIPTION



KEY	Weighing Mode	Parameter Setting
ON/OFF	Powers the Indicator On or Off if held for 2 seconds	Exit
HOLD	1. Peak hold - Grabs the highest weight 2. Data hold - Holds the current weight value 3. Auto hold	Confirm
ZERO	Zero's the scale Tare's the scale	Move Left
UNITS	Shifts between weighing units (kg/lb)	Move Down
DISPLAY	Meaning	
	The scale is at zero	
	The scale is stable	
Gross	Shows you are in Gross weight mode; default mode	
Net	Shows you are in Net weight mode (without tared weight)	
hold	Shows you are in Hold mode	
lb	The weight is shown in pounds	
oz	The weight is shown in ounces	
kg	The weight is shown in kilograms	
	Low battery	

OPERATING INSTRUCTIONS

Powering On or Off

- Press ON/OFF key for 1 second to power on. Machine will self inspect and count from **1 - 9** before entering weighing mode and displaying 0
- Press ON/OFF key for 1 second to power off
- Indicator will auto power off when it has low battery
- Auto power-off in 10/20/60 minutes with no operation can be set in the parameters

Zero/Tare

- The zero function is used only when the scale is empty and is not at gross zero due to material build up
- If the weight on the scale is within the zero range (2% of the max. capacity) and stable and ZERO is pressed, the indicator will zero the scale and stay in gross weighing mode
- The Tare function is used when you only wish to see the current change in weight, not the entire amount of weight that is on the scale
- If the scale is out of the zero range (above 2% of the max. capacity) and stable the indicator will Tare the scale and go into Net weighing mode when ZERO is pressed

Print

- To print press and hold the UNITS key when weighing is stable
- Communication Setting must be set to #2 for Print mode

Hold

There are five different hold functions, you can choose the best option for you and set it the parameter settings

- 1. Peak Hold:** Grabs the highest weight (for materials testing, ie. tension and pulling force)
 - Press the HOLD key then add weight to the scale
 - The indicator will show the highest weight it recorded and hold it on the screen until a higher weight is placed on the scale
- 2. Manual Hold:** Grabs the current weight and holds it so it will not change/fluctuate

- While weighing, press HOLD and the indicator will hold the current weight on the screen until HOLD is pressed again

3. Auto Hold: If the weight on the scale is above 20d and is stable, the indicator will hold that weight on the screen for 3 seconds then go back to general weighing

- Pressing the hold key is unnecessary, holding is done automatically when the scale is stable

4. Average Hold: Used for animal weighing, the indicator will display the average weight sampled from 1-9 seconds (Set in the *HAt* parameter setting)

- Add animal to scale and press HOLD
- Indicator screen will show "*LOC*" for 1-9 seconds, then display the average weight from those seconds
- Press HOLD again to exit holding mode

5. Auto Average Hold: Used for animal weighing, the indicator will display the average weight sampled from 1-9 seconds without the need to press the HOLD key. If the weight on the scale is above 20d (scales division x 20) and is stable, the indicator will start grabbing the average weight sampled from 1-9 seconds (Set in the HAt: parameter setting). In parameter *Hadt* you can set a determined loading time from 1-9 seconds. This is the time you have to load the animal before the scale begins to take the average weight.

- Add animal to scale. Once weight is added to the scale, the scale will wait the set loading time and then the Indicator screen will show "*LOC*" for 1-9 seconds
- It will then display the average weight from those 1-9 seconds for 3 seconds and then repeat the process

CALIBRATION

To Enter Calibration Settings

- Turn indicator off. Then press and hold the HOLD and UNIT key simultaneously while the indicator is turning on (Do this while indicator is counting down)
- The display will show [*CAL* kg], meaning the unit is kg
- Press UNIT if you want to change the unit to lb; Display will change to [*CAL* lb].
- Press HOLD to confirm your unit choice
- The display will most likely show [*FS 5*], meaning the max. capacity is 200kg, (see tables below for other variances)
- Press UNIT to change the capacity range to your scales capacity **Calibration chart for kilogram usage:**

Display	Max. Capacity	Division	Calibration Loading Weight
FS 0	15.00kg	0.005kg	10kg
FS 1	30.00kg	0.01kg	25kg
FS 2	60.00kg	0.02kg	50kg
FS 3	100.00kg	0.02kg	75kg
FS 4	150.00kg	0.05kg	100kg
FS 5	200.00kg	0.05kg	150kg
FS 6	custom	custom	custom

Calibration chart for pound usage:

Display	Max. Capacity	Division	Calibration Loading Weight
FS 0	33.00lb	0.01lb	22.05lb
FS 1	66.00lb	0.02lb	55.12lb
FS 2	132.00lb	0.05lb	110.25lb
FS 3	220.00lb	0.05lb	165.35lb
FS 4	330.0lb	0.1lb	220.5lb
FS 5	440.0lb	0.1lb	330.7lb
FS 6	custom	custom	custom

CALIBRATION cont.

If FS = 6

Please follow the procedure below:

- The display will show [*dp 1*], to indicate how many decimal places you want; press UNIT to change, and press HOLD to confirm (ex. DP 2 = #####.##)
- The display will show [*d 2*], to indicate the division; press UNIT to change, and press HOLD to confirm
- The display will show [*CAP*], to indicate the max. capacity; press HOLD to display the current max. capacity; press ZERO to left shift and UNIT to change the capacity; Then press HOLD to confirm
- The display will show [*LoAd*], to indicate the calibration loading weight; press HOLD to display the current calibration loading weight; press ZERO to left shift and UNIT to change the calibration loading weight; Then press HOLD to confirm
- The display will show [*CALon*] please follow the steps for FS values of 0-6 to complete calibration

For FS values of 0 - 6

Please follow the procedure below:

- The display will show [*CALon*], press HOLD to enter into weight calibration, or press ON/OFF to exit calibration
- The display will show [*noLoAd*] for zero calibration; make sure there is no load on scale, then press HOLD to confirm and zero calibrate
- The display will show [*AdLoAd*] for loading calibration; place calibration weight as defined by the tables above on the scale
- Once the weighing platform is stable, press HOLD to confirm and calibrate
- The display will show [*CALEnd*] when the calibration is complete, press HOLD to save the weight calibration and press ON/OFF to exit and go back to weighing mode

PARAMETER SETTINGS

- Press HOLD and UNIT together to enter the parameter settings
- Use the following diagram to navigate through the parameter settings:

KEY	Function
ON/OFF	Exit
HOLD	Confirm
ZERO	Move Left
UNITS	Move Down

Function	Display	Parameter Settings
Automatic Power Off	OFF 10	0 = turn off auto power off 10 = power off automatically if no change within 10 minutes 30 = power off automatically if no change within 30 minutes 60 = power off automatically if no change within 60 minutes 90 = power off automatically if no change within 90 minutes
Power Saving Mode	BL 1	0 = turn off the backlight 1 = backlight only when the weight changes or keyboard is pressed 2 = constant backlight
Unit Conversion	UnS 1	0 = turn off unit switch function 1 = kg/lb 2 = lb/oz 3 = kg/lb/oz
Hold Function	Hold 1	0 = turn off hold function 1 = Peak hold - Grabs the highest weight 2 = Manual hold - Grabs the current weight 3 = Auto hold - Automatically holds data when stable 4 = Average hold - Averages the weight from a sample of 3 seconds 5 = Auto Average hold - Average hold without pressing HOLD
Hold Time	Ht 1	0 = turn off hold time 1 = 15 second hold time 2 = 30 second hold time 3 = 45 second hold time 4 = 60 second hold time 5 = 90 second hold time
Average Hold Sample Time	HAt 1	1-9 Seconds = How many seconds sampled for the average weight
Loading Time	HAdt 1	1-9 Seconds = How long the scale waits (So you can load the animal on the scale) until it begins to take the average weight
Zero Range (% scale is allowed to zero, anything after will be tared)	2Ero 1	0 = turn off manually zero setting 1 = Initial zero range $\pm 10\%$ max capacity, Manual zero range $\pm 2\%$ 2 = Initial zero range $\pm 100\%$ max capacity, Manual zero range $\pm 100\%$

Negative Range (% it can go negative before an error)	<i>nEgr 1</i>	0 = -20d negative display 1 = 10% MAX negative display 2 = 100% MAX negative display
Communication Setting	<i>trn 1</i>	Set the serial interface data output method: 0 = Turn off serial interface data output 1 = Continuous sending mode, connect computer 2 = Print mode, connect printer 3 = Command request mode, connect computer

Function	Display	Parameter Settings
Baud Rate	<i>bAud 1</i>	1 = 9600bit/s 2 = 4800bit/s 3 = 2400bit/s 4 = 1200bit/s 5 = 600bit/s

HELPFUL DEFINITIONS

Division: The amount of increments a scale offers. How accurate the scale can be

Capacity: the maximum amount the scale can contain

Zero Range: % of the max capacity that the scale is allowed to zero, anything above this percentage number will be tared.

Initial Zero Range: The percentage of weight allowed on the scale when indicator is powered on that will automatically zero (anything above this percent will be tared).

example: If initial zero range is set to 10% of the max. capacity and your max. capacity is 100lbs, you can place up to 10lbs of weight on the scale and when the indicator is powered on, it will automatically zero out the weight.

Manual Zero Range: The percentage of weight allowed on the scale where the indicator will let you manually zero by pressing the ZERO key (anything above this percent will be tared).

Negative Range: How far you can go in the negative direction before displaying an error code

Baud Rate: The rate at which information is transferred in a communication channel.
example: In the serial port context, "9600 baud" means that the serial port is capable of transferring a maximum of 9600 bits per second.

TROUBLESHOOTING

Error	Reason	Solution
<i>UUUUUU</i>	<ol style="list-style-type: none"> 1. Overload 2. Wrong connection with load cell 3. Load cell has quality problem 	<ol style="list-style-type: none"> 1. Reduce the weight 2. Check load cell connection 3. Inspect load cell; Check the input/output
<i>nnnnnnnn</i>	<ol style="list-style-type: none"> 1. Calibration is no good 2. Wrong connection with load cell 3. Load cell has quality problem 	<ol style="list-style-type: none"> 1. Make sure scale is level 2. Check load cell connection 3. Check load cell input and output resistance
<i>ERR1</i>	During calibration, weight is not used or the weight is above the max. capacity	Use correct weight within the defined range
<i>ERR2</i>	During calibration, the weight is below the minimum required weight	The calibration weight minimum is 10% of the max. capacity set in C04. Recommended to use 60%-80% of max. capacity if possible
<i>ERR3</i>	During calibration, the input signal is negative	<ol style="list-style-type: none"> 1. Check all wire connections 2. Check load cell 3. Recalibrate 4. PCB replacement needed if steps 1-3 fail
<i>ERR4</i>	During calibration signal is unstable	After the platform is stable, start calibration
<i>ERR5</i>	EEPROM Error	Change PCB

CONNECTORS

Connecting load cells to the indicator

- The indicator can connect with 4 load cells of 350Ω at most. Use the quick disconnect connector

Quick Disconnect

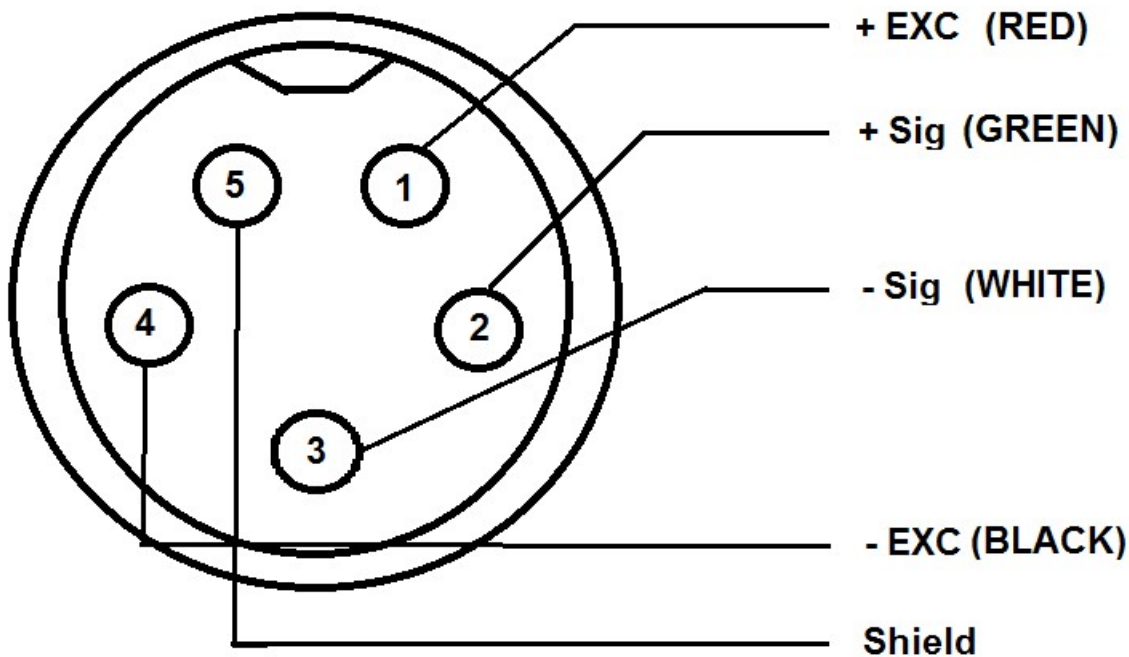
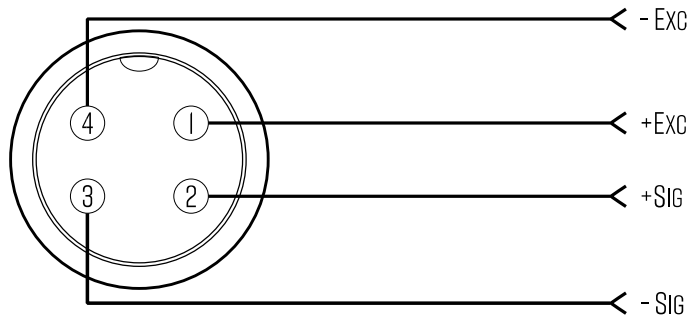

DB9 Connection (9 pin Serial Connector)

The DB9 9 pin serial connector is used for different purposes depending on the indicator model

- Figure 4 shows the pin assignment on the DB9 9 pin connector

DB9 SERIAL CONNECTOR PINOUT

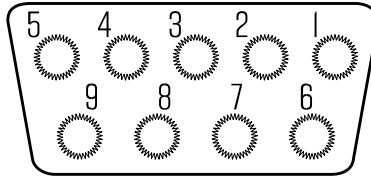

DB9 Pin Description

DB9 Pin	Definition	Function
2	TXT	Transmit Data
3	RXD	Receive Data
5	GND	Ground Interface

COMMUNICATION MODES

Continuously send mode: the indicator continuously sends the data to the RS232 port

Manually send mode: Press UNIT for 1 second to send the current data to the RS232 port

Command Send Mode: From a computer send ASCII R character (hexadecimal 52) to the indicators RS232 port and the indicator will respond with the current data

Communication Format is done using ASCII as shown below:

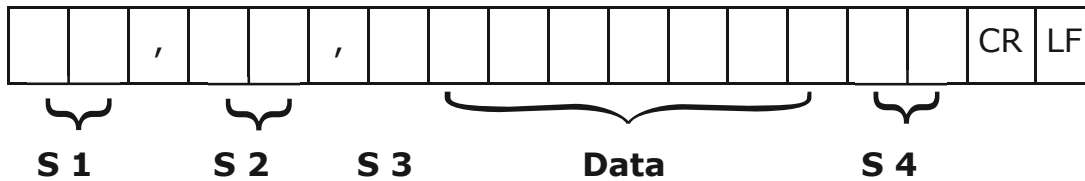

S1: weight status, ST=standstill, US=not standstill, OL=overload

S2: weight mode, GS=gross mode, NT=net mode

S3: weight of positive and negative, "+" or "-"

Data: weight value, including decimal point

S4: "kg" or "lb"

CR: carriage return

LF: line feed

Manual Send Mode Print out example:

ST, GS+	5.12KG
---------	--------

ST = Stable

GS = Gross

+ = Weight is positive

5.12 = Weight

KG = Unit measurement

SPECIFICATIONS

