

LINE: BENCH SCALES

MODEL: EQB-50/100 & EQB-100/200



USE
<ul style="list-style-type: none"> • Storage companies • Markets • Shipping departments • Supermarkets • House hold suppliers • Steel and aluminum foundries • Office suppliers • Manufacturers • Etc

CAPACITIES AND DIMENSIONS			
MODEL	Capacity	Minimum division	Plate Dimensions
EQB-50/100	50 kg/100 lb	10 gr /0.02 lb	19 X15" IN (48 X 38 cm)
EQB-100/200	100 kg/200 lb	20 gr /0.05 lb	19 X15" IN (48 X 38 cm)

BENEFITS

- Very precise, 5000 divisions
- Easy to use
- Heavy duty use
- Toggles between kg and lb
- PC or Printer communication function
- Operates with rechargeable battery (Approximately 200 hours) or electrical power supply.

LINE: BENCH SCALES

MODEL: EQB-50/100 & EQB-100/200

BENEFITS

SPECIFICATIONS

 **EASY TO USE**
So simple to use that anyone can operate it with only a minute training

 **BUILT TO LAST**
Its solid structure and design, guarantee years of continuous trouble free operation.

	EQB-50/100	EQB-100/200
Capacity	50 kg/100 lb	100 kg/200 lb
Minimum division	0.01 kg/0.02 lb	0.02 gr/0.05 lb
Display	Liquid crystal display	
Backlight	Included	
Power Supply	110v/60hz (220v/50 hz Optional)	
Power supply adapter	Included	
Cars lighter adapter	Optional	
Rechargeable Battery	Included (approximately 200 hours)	
Serial port	Included	
Plate Dimensions	15 x19" IN (38 x 48 cm)	
Maximum tare	25 kg/50 lb	50 kg/100 lb
Operation temperature	14 to 104 °F (-10 to 40 °C)	
Storage Temperature	-4 to 122 °F (-20 to 50 °C)	
Net weight	35.5 lb / 16.1 kg	35.5 lb / 16.1 kg
Shipping weight	44.7 lb /20.3 kg	44.7 lb /20.3 kg

OPTIONAL ACCESORIES



Stainless steel plate



Car lighter adapter to plug in the scale



Remote module kit



Enameled carbon steel table (29 inch) with lead free epoxy finish

OPERATES ANYWHERE

The EQB operates anywhere with a long lasting rechargeable battery (90 Hrs, approx.)



PC COMMUNICATION FUNCTION

Includes PC or printer interface through RS-232 serial port



EASY TO READ DISPLAY

Just place the product on the platter and instantly read the weight on the display. Saves time and money.



WEIGHS AMPLE PRODUCTS WITHOUT A PROBLEM ON ITS LARGE PLATE

The EQB series was designed to weigh voluminous products. Adjustable indicator allows for easy display reading in many directions.

DIMENSIONS

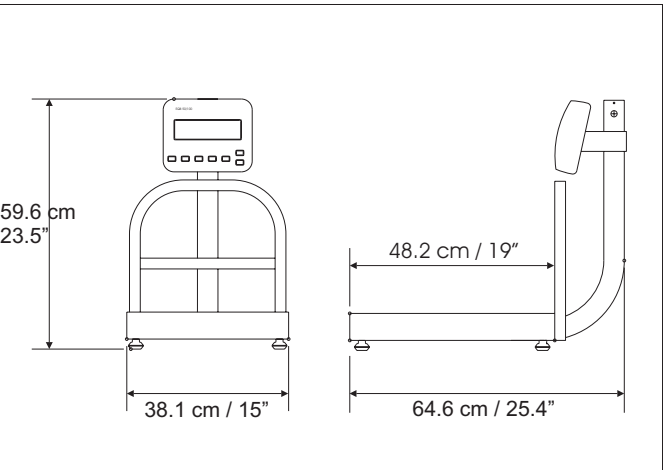

*Available only in scales ordered under this spec

DISTRIBUTED BY

